

DURAMOV® Plastic Cable Carriers

DURAMOV® 塑料电缆拖链

附件 | 分隔片 Accessories | Separators

■ C02竖分隔片 Vertical separators



- 分隔片，将链内空间按需要分隔开电缆、油管、气管等起到保护作用
- 具有较高强度的分隔片，可稳固的装备于拖链中
- 同时满足安装简单快速
- The separator separates inside space of the carrier to protect cables, oil hoses, gas hoses, etc.
- Separator with high strength, can be firmly fitted in carrier
- Quickly and easily installation

DURAMOV® Accessories

www.csb-ep.com
sales@csb-ep.com

电话: 0573 84186133/84185527
Tel: 0086 573 84187009

标准尺寸 Standard dimensions

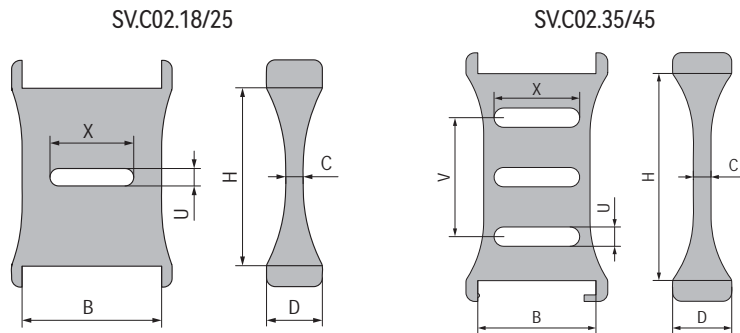

🛒 产品编码 Part No.:

SV.C02.25

拖链内高 Inner Height

拖链型号 Carrier type

分隔片系列 Separator series

产品编码 Part No.	产品编码 Part No.	H ⁰ _{-0.25} [mm]	X [mm]	V [mm]	C [mm]	D [mm]	U [mm]	B [mm]
SV.C02.18	SV.C02E.18	18	12	/	2.5	8	3	20
SV.C02.25	SV.C02E.25	25	12	/	2.5	8	3	20
SV.C02.35	SV.C02E.35	35	12	14.6	3	10	3	20
SV.C02.45	SV.C02E.45	45	12	18	3	10	3	22



可沿横杆自由移动
Move freely along the crossbar

附件 | 分隔片 Accessories | Separators

■ C03竖分隔片 Vertical separators



- 分隔片，将链内空间按需要分隔开电缆、油管、气管等起到保护作用
- 具有较高强度的分隔片，可稳固的装备于拖链中
- 同时满足安装简单快速
- The separator separates inside space of the carrier to protect cables, oil hoses, gas hoses, etc.
- Separator with high strength, can be firmly fitted in carrier
- Quickly and easily installation

标准尺寸 Standard dimensions

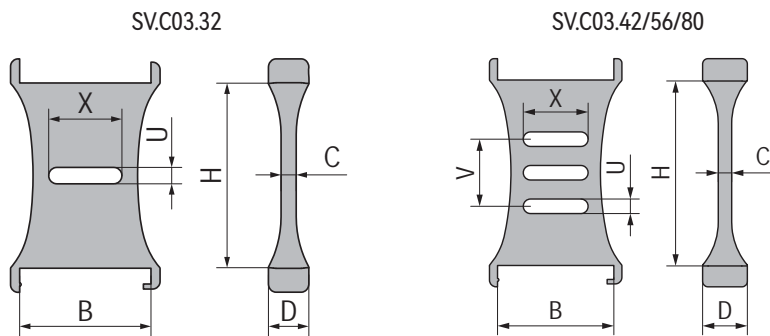

产品编码 Part No.:

SV.C03.32

- 拖链内高 Inner Height
- 拖链型号 Carrier type
- 分隔片系列 Separator series

产品编码 Part No.	$H_{-0.25}^0$ [mm]	X [mm]	V [mm]	C [mm]	D [mm]	U [mm]	B [mm]
SV.C03.32	32	12	/	3	8	3	26
SV.C03.42	42	12	17	3	10	3	26
SV.C03.56	56	15	22.7	4	12	4	30
SV.C03.80	80	15	40	4	10	4	30



可沿横杆自由移动
Move freely along the crossbar

DURAMOV® Plastic Cable Carriers

DURAMOV® 塑料电缆拖链

附件 | 分隔片 Accessories | Separators

■ C04竖分隔片 Vertical separators



- 将链内空间按需要分隔开电缆、油管、气管等起到保护作用
- 具有较高强度的分隔片，可稳固的装备于拖链中
- 同时满足安装简单快速
- The separator separates inside space of the carrier to protect cables, oil hoses, gas hoses, etc.
- Separator with high strength, can be firmly fitted in carrier
- Quickly and easily installation

标准尺寸 Standard dimensions

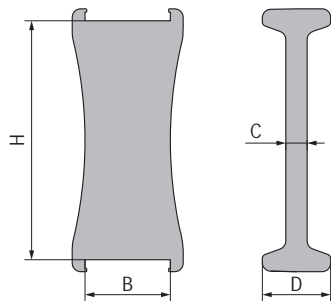

产品编码 Part No.:

SV.C04.28

拖链内高 Inner Height
拖链型号 Carrier type
分隔片系列 Separator series

产品编码 Part No.	$H_{-0.25}^0$ [mm]	C [mm]	D [mm]	B [mm]
SV.C04.28	28	2.5	8	10



可沿横杆自由移动
Move freely along the crossbar

附件 | C03电缆拖链长行程拖行-滑行垫 Accessories | Sliding pads for cable carriers

■ C03电缆拖链长行程拖行-滑行垫 Horizontal separators-Sliding pads for cable carriers



- 用于C03塑料电缆拖链长行程保护
 - 经过摩擦优化耐磨复合塑料制成
 - 坚固耐用，延长电缆拖链寿命
 - 作为独立部件供货
- Used for C03 cable carriers long stroke protection
 - Made of friction-optimized wear-resistant composite plastic
 - Rugged and durable, extend the life of the cable carrier
 - Supplied as a individual component

标准尺寸 Standard dimensions

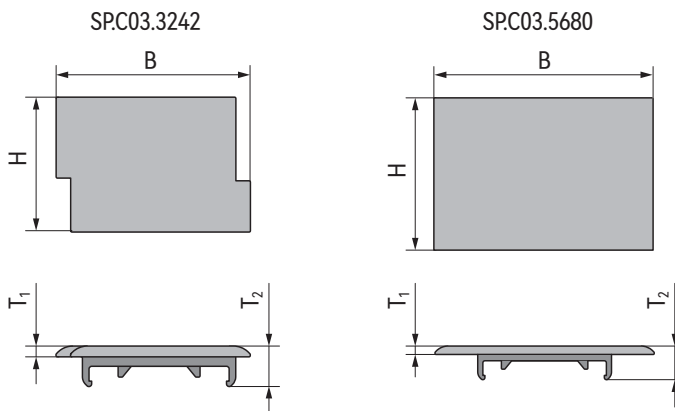

产品编码 Part No.:

SP.C03.3242

- 编号 Code
- 拖链型号 Carrier type
- 滑行垫系列 Sliding pads series

产品编码 Part No.	适配拖链 Suitable for carriers	B [mm]	H [mm]	T ₁ [mm]	T ₂ [mm]	重量 Weight [g]
SPC03.3242	C03.32 / C03.42	37	25	2	7.5	3.5
SPC03.5680	C03.56 / C03.80	53	36	2	8	7



可拆卸, 安装简易
Removable and easy
to install

未安装滑行垫
Without sliding pads



滑行垫安装后
Assembled sliding pads



DURAMOV® Plastic Cable Carriers

DURAMOV® 塑料电缆拖链

附件 | 分隔片 Accessories | Separators

■ 横分隔片 Horizontal separators



- 可用于许多直径电缆应用，横分隔片可以放置适合宽度
- C03.42和C03.56提供了3个不同高度横向分隔槽位
- 横分隔片中的竖分隔片可在水平方向自由移动
- Horizontal separators are available for many diameter cable applications
- Three different height for C03.42 and C03.56
- The vertical separator in the horizontal separator can move freely in the horizontal direction

标准尺寸 Standard dimensions

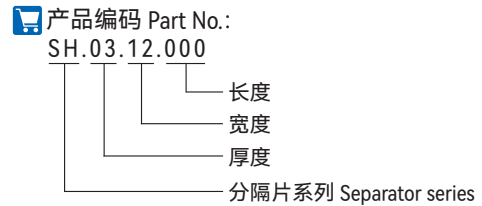
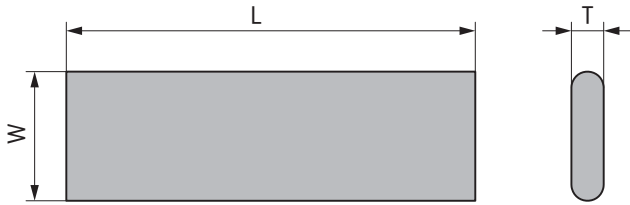

产品编码 Part No.	L [mm]	W [mm]	T [mm]	重量 Weight [g]
SH.03.12.038	38	12	3	2.5
SH.03.12.048	48	12	3	3.2
SH.03.12.050	50	12	3	3.3
SH.03.12.057	57	12	3	3.8
SH.03.12.060	60	12	3	4.0
SH.03.12.067	67	12	3	4.5
SH.03.12.075	75	12	3	5.0
SH.03.12.077	77	12	3	5.1
SH.03.12.080	80	12	3	5.3
SH.03.12.087	87	12	3	5.8
SH.03.12.100	100	12	3	6.6
SH.03.12.103	103	12	3	6.8
SH.03.12.125	125	12	3	8.3
SH.03.12.150	150	12	3	9.9
SH.03.12.175	175	12	3	11.6
SH.03.12.200	200	12	3	13.2
SH.04.15.100	100	15	4	11.0
SH.04.15.125	125	15	4	13.8
SH.04.15.150	150	15	4	16.6
SH.04.15.175	175	15	4	19.3
SH.04.15.200	200	15	4	22.1
SH.04.15.225	225	15	4	24.9
SH.04.15.250	250	15	4	27.6

拖链类别 Plastic cable carriers	拖链型号 Cable carrier specifications	横分隔片 Horizontal separators	最大安装数量 Max. installation quantities [pcs/link]
C02 通用型拖链 Universal cable carriers	C02.18	SH.03.12.000	1
	C02.25	SH.03.12.000	1
	C02.35	SH.03.12.000	1
	C02.45	SH.03.12.000	2
C02E 抗静电拖链 ESD cable carriers	C02E.18	SH.03.12.000	1
	C02E.25	SH.03.12.000	1
	C02E.35	SH.03.12.000	1
	C02E.45	SH.03.12.000	2
C03 重载型拖链 High load cable carriers	C03.32	SH.03.12.000	1
	C03.42	SH.03.12.000	2
	C03.56	SH.04.15.000	3
	C03.80	SH.04.15.000	3

附件 | 波纹管 Accessories | Bellows

拖链产品编码 Cable carriers part No.	拖链内高 Inner height [mm]	拖链外高 Outer height [mm]	适配波纹管 Bellows	适配波纹管支架 Brackets	适配波纹管外径 Bellows outer diameter [mm]
C02.35	35	50	AD13.0 至 to AD25.0	VHB-AD13.0 至 to VHB-AD25.0	≤25
C02.45	45	64	AD13.0 至 to AD28.5	VHB-AD13.0 至 to VHB-AD28.5	≤28.5
C03.32	32	54	AD13.0 至 to AD21.2	VHB-AD13.0 至 to VHB-AD21.2	≤21.2
C03.42	42	64	AD13.0 至 to AD28.5	VHB-AD13.0 至 to VHB-AD28.5	≤28.5
C03.56	56	84	AD13.0 至 to AD42.5	VHB-AD13.0 至 to VHB-AD42.5	≤42.5
C03.80	80	108	AD13.0 至 to AD54.5	VHB-AD13.0 至 to VHB-AD54.5	≤54.5

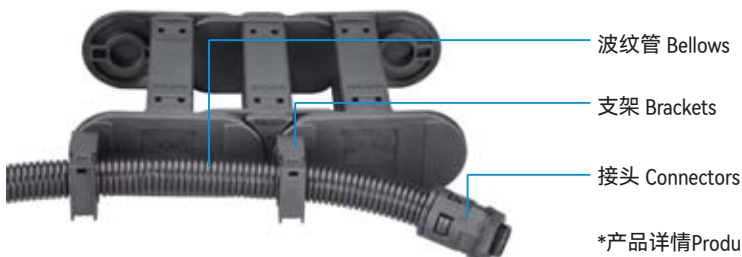

*产品详情Product information: P86-P91

DURAMOV® Plastic Cable Carriers

DURAMOV® 塑料电缆拖链

附件 | 消除应力元件 Accessories | Strain relief elements

■ C02 C型支架 C-profile brackets

安装在拖链接头内部 Mounted on the inside of the carrier brackets



- 铝合金材质，表面阳极氧化
- 消除应力元件可在导向槽内运动
- Aluminum alloy, surface anodized
- The tiewrap elements can move within the guide slot

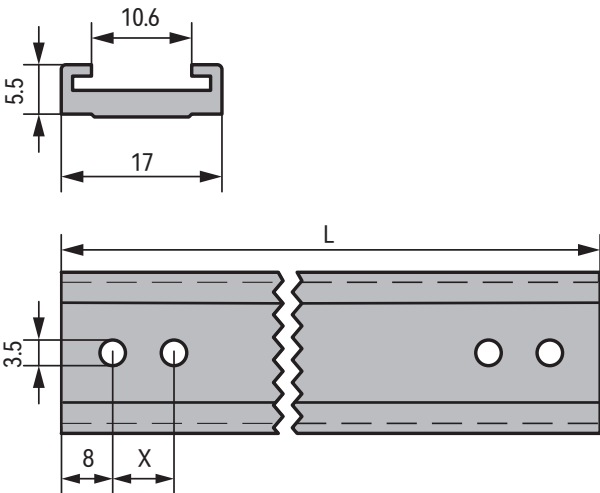

产品编码 Part No.	X (C02.18/25) [mm]	X (C02.35/45) [mm]	L [mm]
CB.C02.038.AL	8	10	38
CB.C02.048.AL	8	10	48
CB.C02.050.AL	8	10	50
CB.C02.057.AL	8	10	57
CB.C02.060.AL	8	10	60
CB.C02.067.AL	8	10	67
CB.C02.077.AL	8	10	77
CB.C02.080.AL	8	10	80
CB.C02.087.AL	8	10	87
CB.C02.100.AL	8	10	100
CB.C02.103.AL	8	10	103
CB.C02.125.AL	8	10	125
CB.C02.150.AL	8	10	150
CB.C02.175.AL	8	10	175

产品编码 Part No.:
CB.C02.038.AL

材料铝合金 Materials: Aluminum
拖链内宽 Inner width
拖链系列 Carrier series
支架系列 Bracket series

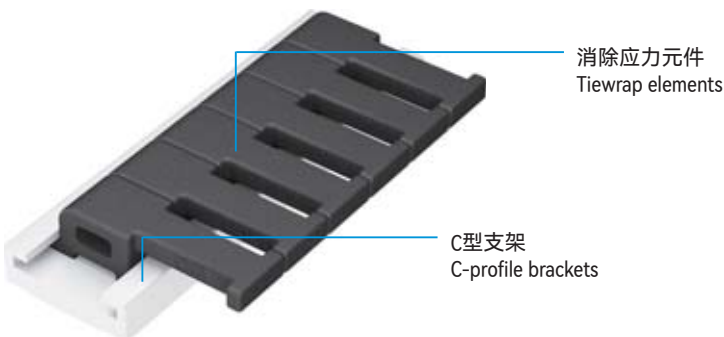

附件 | 消除应力元件 Accessories | Strain relief elements
■ C03 C型支架 C-profile brackets

安装在拖链接头内部 Mounted on the inside of the carrier brackets

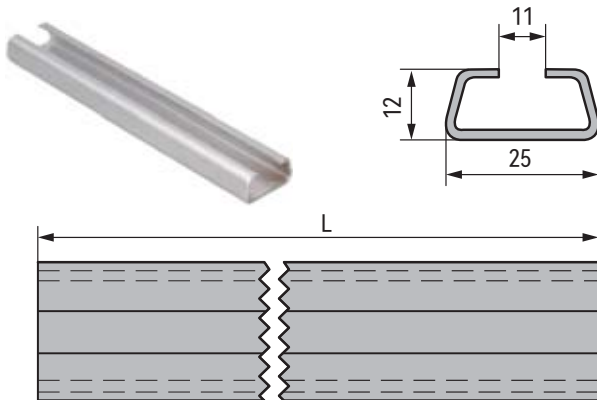

产品编码 Part No.:
CB.C03.050.GS

- ES:材料不锈钢 Stainless steel
- GS:镀锌钢 Galvanized steel
- 拖链内宽 Inner width
- 拖链系列 Carrier series
- 支架系列 Bracket series

产品编码 Part No.	产品编码 Part No.	L [mm]
CB.C03.050.GS	CB.C03.050.ES	50
CB.C03.075.GS	CB.C03.075.ES	75
CB.C03.100.GS	CB.C03.100.ES	100
CB.C03.125.GS	CB.C03.125.ES	125
CB.C03.150.GS	CB.C03.150.ES	150
CB.C03.175.GS	CB.C03.175.ES	175
CB.C03.200.GS	CB.C03.200.ES	200
CB.C03.225.GS	CB.C03.225.ES	225
CB.C03.250.GS	CB.C03.250.ES	250

■ C03 C型支架 C-profile bracket for heavy-duty applications

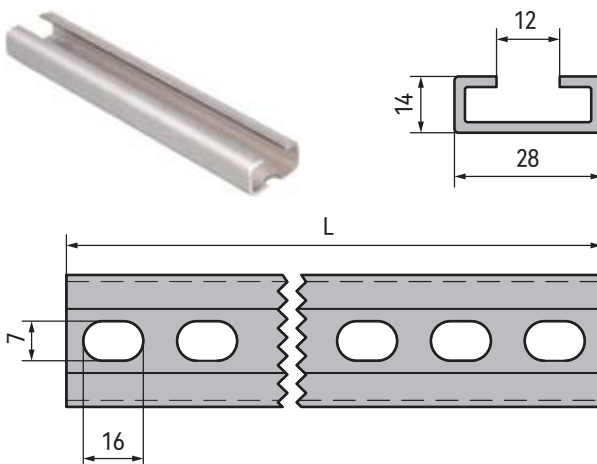
安装在拖链接头外部 Mounted on the outside of the carrier brackets

产品编码 Part No.:
CB.HD.050.ES

- ES:材料不锈钢 Stainless steel
- GS:镀锌钢 Galvanized steel
- 拖链内宽 Inner width
- 重载系列 Heavy-duty series
- 支架系列 Bracket series

产品编码 Part No.	产品编码 Part No.	L [mm]
CB.HD.050.GS	CB.HD.050.ES	50
CB.HD.075.GS	CB.HD.075.ES	75
CB.HD.100.GS	CB.HD.100.ES	100
CB.HD.125.GS	CB.HD.125.ES	125
CB.HD.150.GS	CB.HD.150.ES	150
CB.HD.175.GS	CB.HD.175.ES	175
CB.HD.200.GS	CB.HD.200.ES	200
CB.HD.225.GS	CB.HD.225.ES	225
CB.HD.250.GS	CB.HD.250.ES	250

DURAMOV® Plastic Cable Carriers

DURAMOV® 塑料电缆拖链

附件 | 消除应力元件 Accessories | Strain relief elements

■ C02 消除应力元件 Tiewrap elements

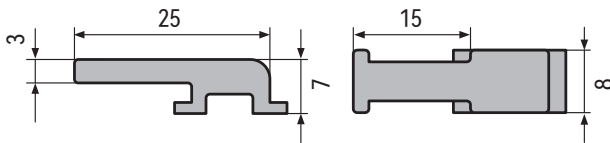

- 作为独立部件供货
- 适用C型支架，带梳齿状应力元件
- 更方便固定电缆，易于拆装
- 节约安装时间，空间、成本，紧凑的模块化设计
- Available as an individual component
- Can be clipped into C-profile bracker
- Easy to assemble and fix cables
- Save assemble time and space,compact modular design

产品编码 Part No.:

TE.C02.08.15

梳齿长度 Tiewrap tooth length

宽度 Width

拖链系列 Carrier series

去应力元件 Tiewrap elements

■ C03 消除应力元件 Tiewrap elements

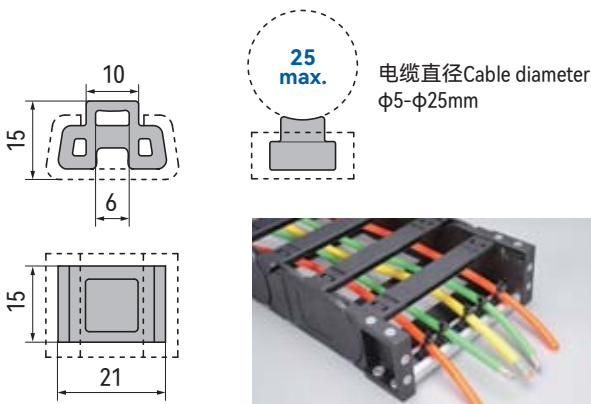

- 作为独立部件供货
- 适用C型支架，配合扎带使用
- 更方便固定电缆，易于拆装
- 节约安装时间，空间、成本，紧凑的模块化设计
- Available as an individual component
- Used with C-profile bracker and tiewraps
- Easy to assemble and fix cables
- Save assemble time and space,compact modular design

产品编码 Part No.:

TE.C03.15.06

最大扎带宽度 Max. tiewrap width

底座宽度 Block width

拖链系列 Carrier series

去应力元件 Tiewrap elements

附件 | 电缆夹 Accessories | Cable clamp



标准尺寸 Standard dimensions

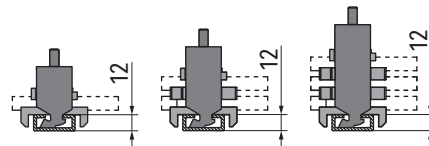
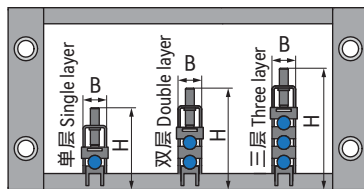

产品编码 Part No.:

CFX12.1.E

空白Blank: 碳钢 Carbon steel
E: 不锈钢 Stainless steel

1: 单层 Single layer
2: 双层 Double layer
3: 三层 Three layer

电缆最大直径 Cable max. diameter
电缆夹系列 Cable clamp series

单层电缆夹 Single layer cable clamp:

产品编码(碳钢) Part No. (Carbon steel)	产品编码(不锈钢) Part No. (Stainless steel)	直径 Diameter [mm]	B [mm]	H [mm]	重量 Weight [g]
CFX12.1	CFX12.1.E	06-12	16	48	30
CFX14.1	CFX14.1.E	12-14	18	50	33
CFX16.1	CFX16.1.E	14-16	20	52	36
CFX18.1	CFX18.1.E	16-18	22	54	39
CFX20.1	CFX20.1.E	18-20	24	56	42
CFX22.1	CFX22.1.E	20-22	26	58	45

产品编码(碳钢) Part No. (Carbon steel)	产品编码(不锈钢) Part No. (Stainless steel)	直径 Diameter [mm]	B [mm]	H [mm]	重量 Weight [g]
CFX26.1	CFX26.1.E	22-26	30	67	48
CFX30.1	CFX30.1.E	26-30	34	71	48
CFX34.1	CFX34.1.E	30-34	38	75	51
CFX38.1	CFX38.1.E	34-38	42	79	54
CFX42.1	CFX42.1.E	38-42	46	83	60

双层电缆夹 Double layer cable clamp:

产品编码(碳钢) Part No. (Carbon steel)	产品编码(不锈钢) Part No. (Stainless steel)	直径 Diameter [mm]	B [mm]	H [mm]	重量 Weight [g]
CFX12.2	CFX12.2.E	06-12	16	69	47
CFX14.2	CFX14.2.E	12-14	18	71	52
CFX16.2	CFX16.2.E	14-16	20	75	57
CFX18.2	CFX18.2.E	16-18	22	79	62
CFX20.2	CFX20.2.E	18-20	24	83	67

产品编码(碳钢) Part No. (Carbon steel)	产品编码(不锈钢) Part No. (Stainless steel)	直径 Diameter [mm]	B [mm]	H [mm]	重量 Weight [g]
CFX22.2	CFX22.2.E	20-22	26	87	72
CFX26.2	CFX26.2.E	22-26	30	105	77
CFX30.2	CFX30.2.E	26-30	34	113	82
CFX34.2	CFX34.2.E	30-34	38	121	88

三层电缆夹 Three layer cable clamp:

产品编码(碳钢) Part No. (Carbon steel)	产品编码(不锈钢) Part No. (Stainless steel)	直径 Diameter [mm]	B [mm]	H [mm]	重量 Weight [g]
CFX12.3	CFX12.3.E	06-12	16	86	64
CFX14.3	CFX14.3.E	12-14	18	92	69
CFX16.3	CFX16.3.E	14-16	20	98	74
CFX18.3	CFX18.3.E	16-18	22	104	79

产品编码(碳钢) Part No. (Carbon steel)	产品编码(不锈钢) Part No. (Stainless steel)	直径 Diameter [mm]	B [mm]	H [mm]	重量 Weight [g]
CFX20.3	CFX20.3.E	18-20	24	110	84
CFX22.3	CFX22.3.E	20-22	26	116	89
CFX26.3	CFX26.3.E	24-26	30	128	99
CFX30.3	CFX30.3.E	28-30	34	140	109